

SECTION A-A

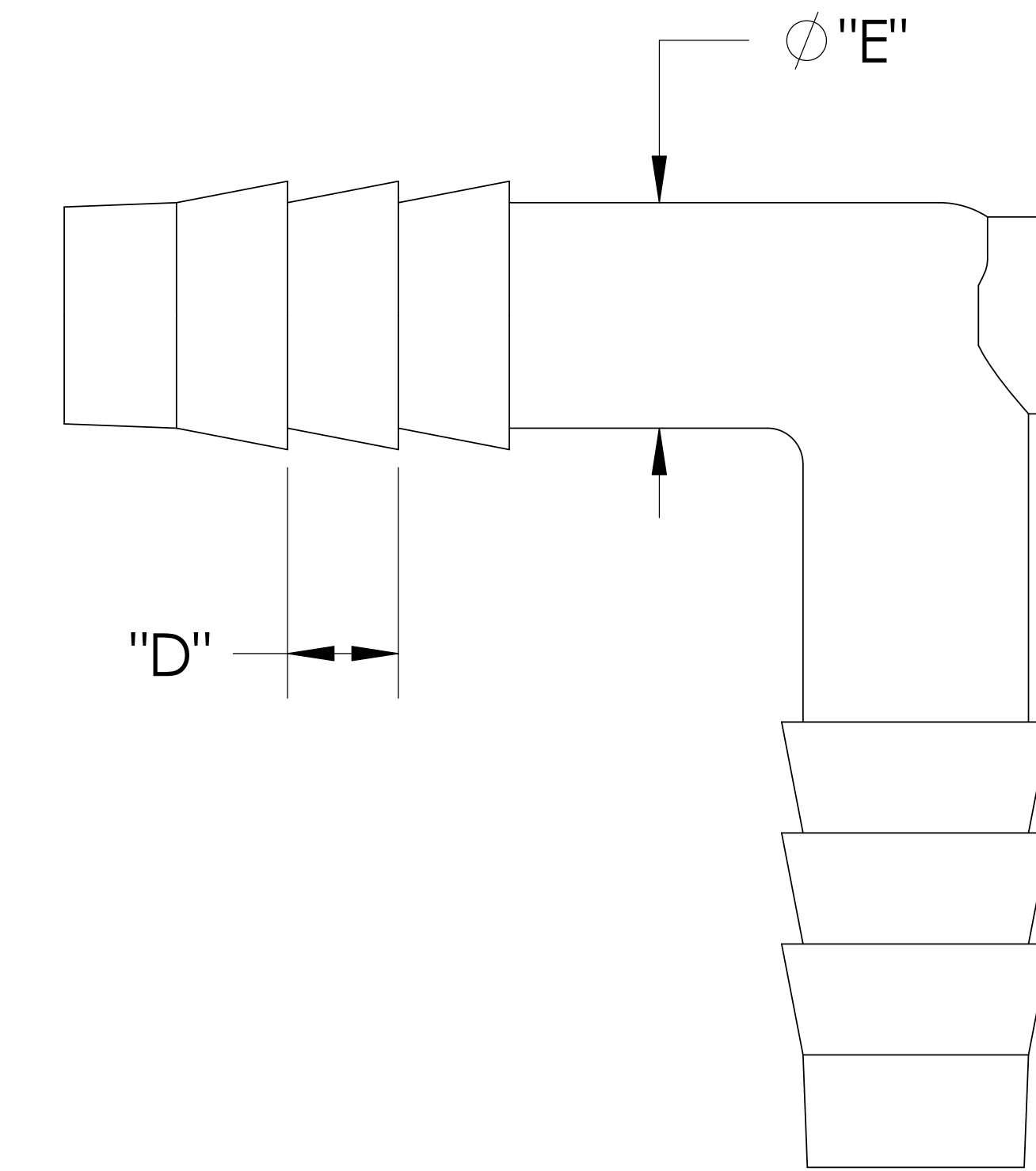
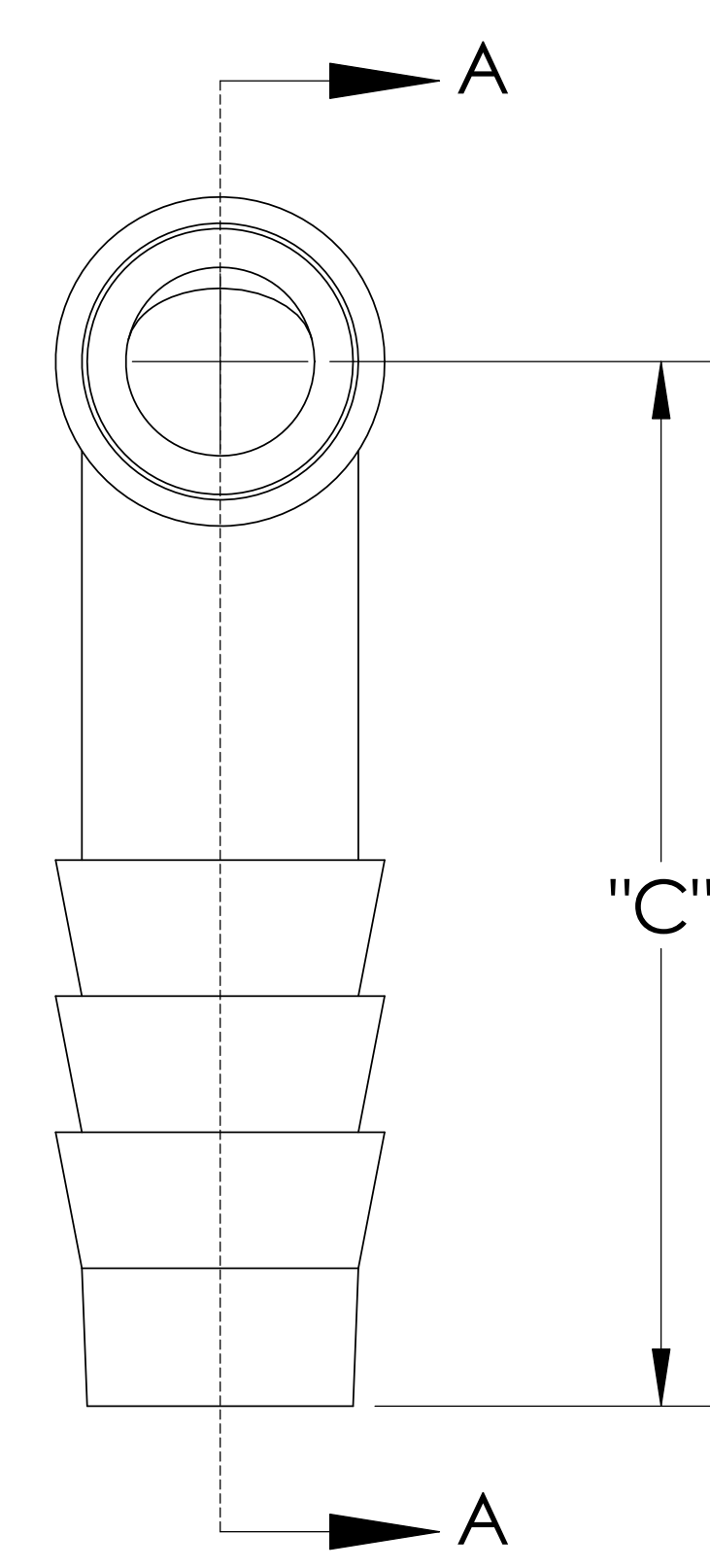

CATALOG NO.	DESCRIPTION	MATERIAL	DIM "A"	DIM "B"	DIM "C"	DIM "D"	DIM "E"
TE2055-T/PP	5/16 X 5/16 PP	POLYPROPYLENE	.370	.220	1.185	.155	.310
TE2055-T/P	5/16 X 5/16 P	POLYETHYLENE	.365	.216	1.16	.145	.310
TE2055-T/N	5/16 X 5/16 N	NYLON	.375	.215	1.19	.155	.315

SHOWN

NOTES:
 1) POLYPROPYLENE HAS COLOR OPTIONS:
 BLACK = TE2055-T/PPB
 NATURAL = TE2055-T/PPN

PROPRIETARY AND CONFIDENTIAL
 THE INFORMATION CONTAINED IN THIS DRAWING IS THE SOLE PROPERTY OF THOGUS PRODUCTS COMPANY. ANY REPRODUCTION IN PART OR AS A WHOLE WITHOUT THE WRITTEN PERMISSION OF THOGUS PRODUCTS COMPANY IS PROHIBITED.

REV	WRO#	DESCRIPTION
D	95.00035	CONVERTED TO 3D FORMAT
UNLESS OTHERWISE SPECIFIED: DIMENSIONS ARE IN INCHES TOLERANCES: ANGULAR: ±0.5° X.X = ± 0.1 X.XX = ± 0.05 X.XXX = ± 0.015 REMOVE ALL SHARP EDGES AND BURRS BLEND ALL RADII TO 0.01IN INTERPRET GEOMETRIC TOLERANCING PER: ANSI Y 14.5 1994 MATERIAL: PP, P, N FINISH: NA THIRD ANGLE PROJECTION: 		
HISTORY		

	NAME	DATE
DRAWN	KDJ	10/22/10
CHECKED	KDJ	10/22/10
ENG APPR.		XX/XX/XX
MFG APPR.		XX/XX/XX
Q.A.		XX/XX/XX
COMMENTS:		

33490 PIN OAK, AVON LAKE, OH 44012
TITLE:
BARB ELBOW, 5/16" X 5/16"

SIZE B	DWG. NO. TE2055-T	REV C
SCALE: 2:1	MASS:	SHEET 1 OF 1

DO NOT SCALE DRAWING