

UNCONTROLLED IF PRINTED; CONTROLLED DOCUMENT LOCATED IN IQMS DOCUMENT CONTROL

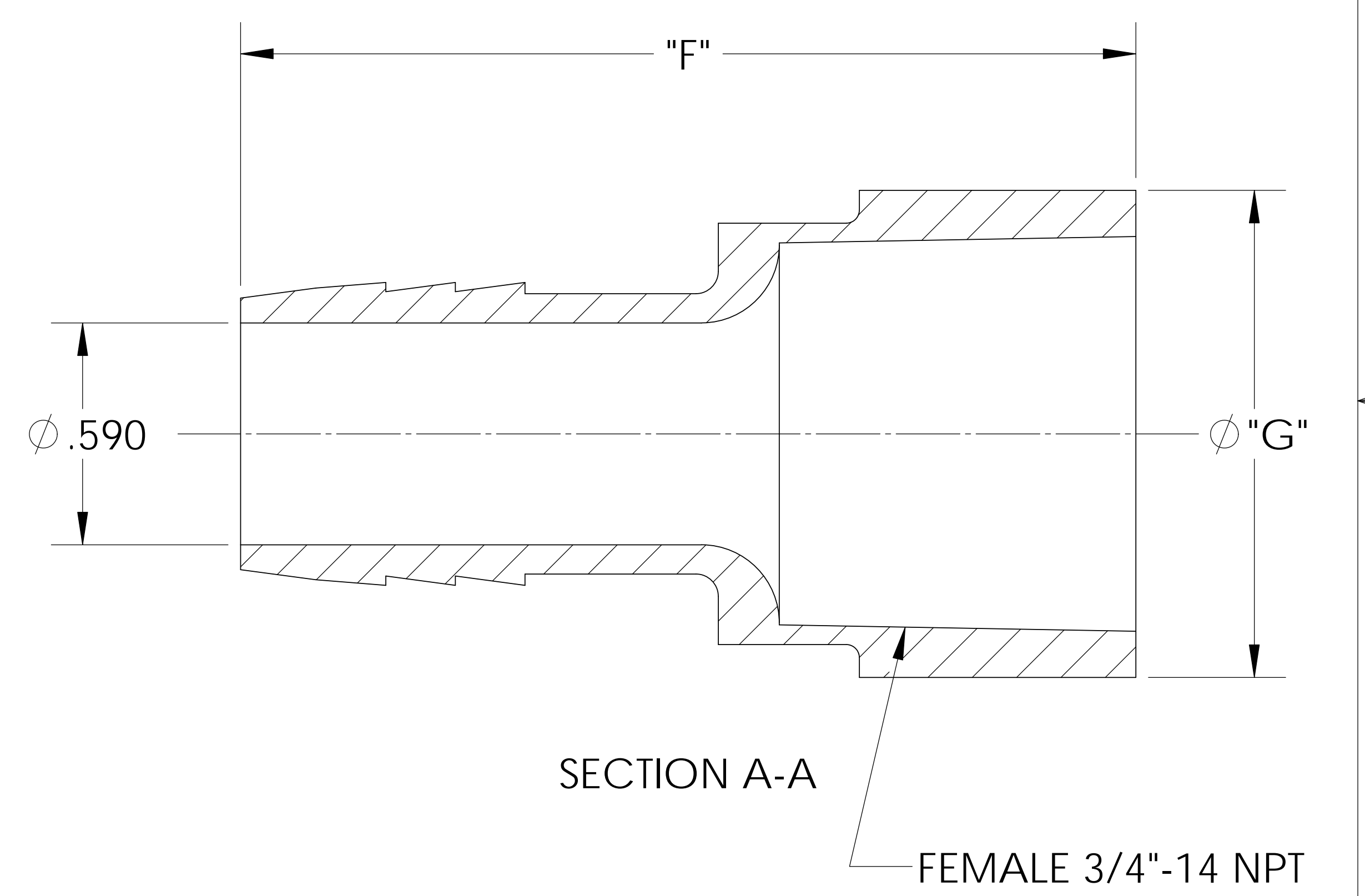
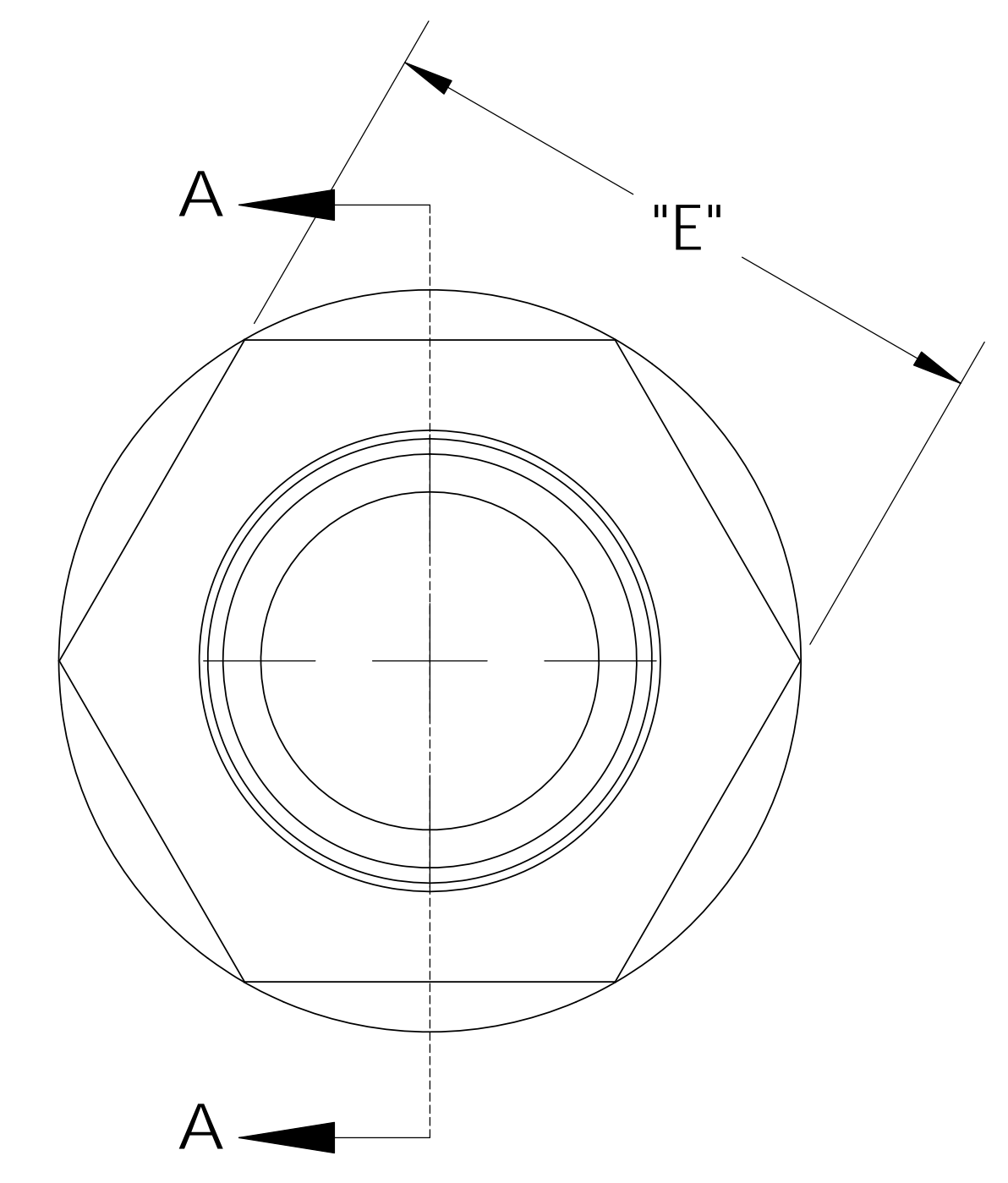
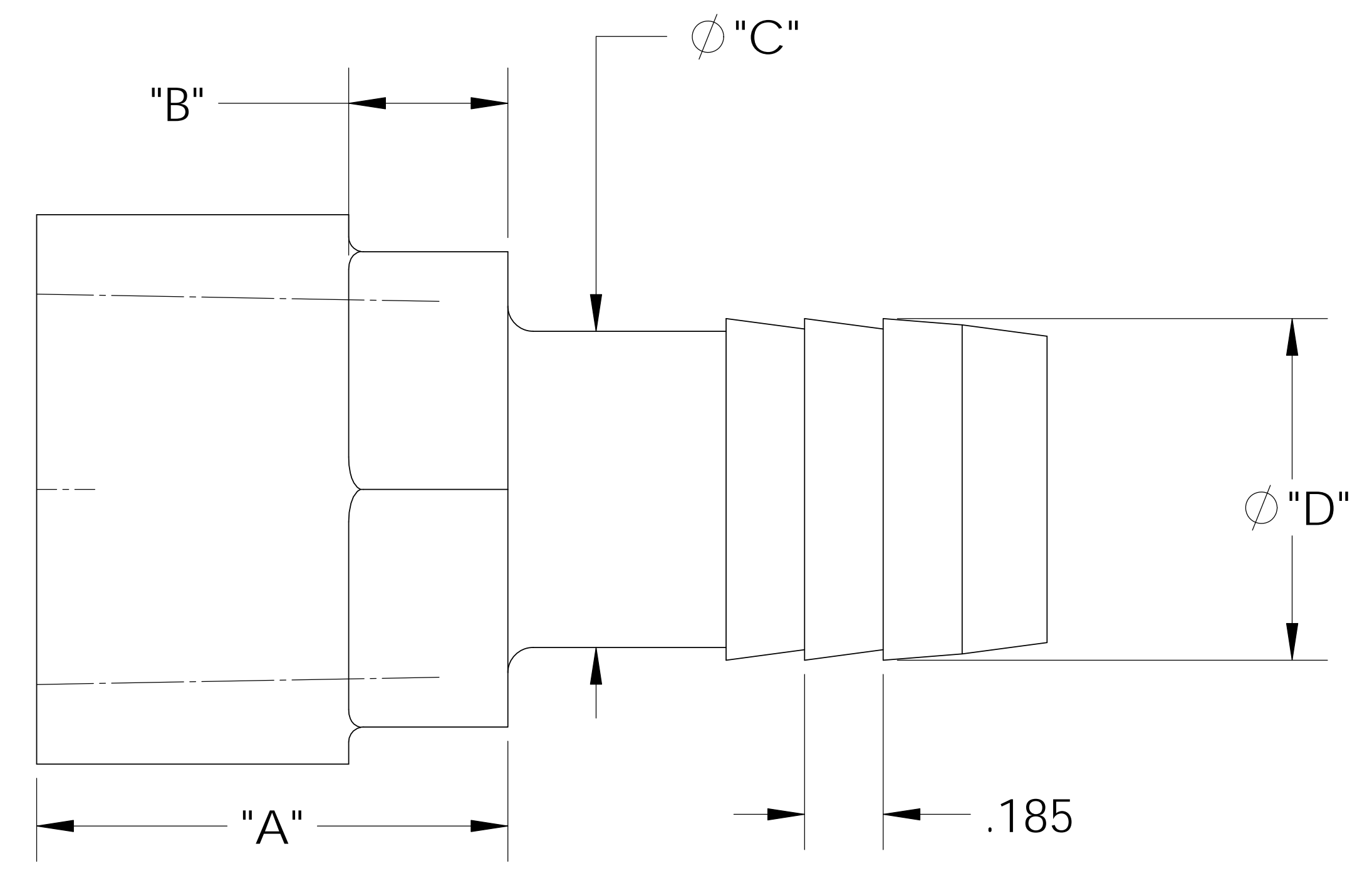
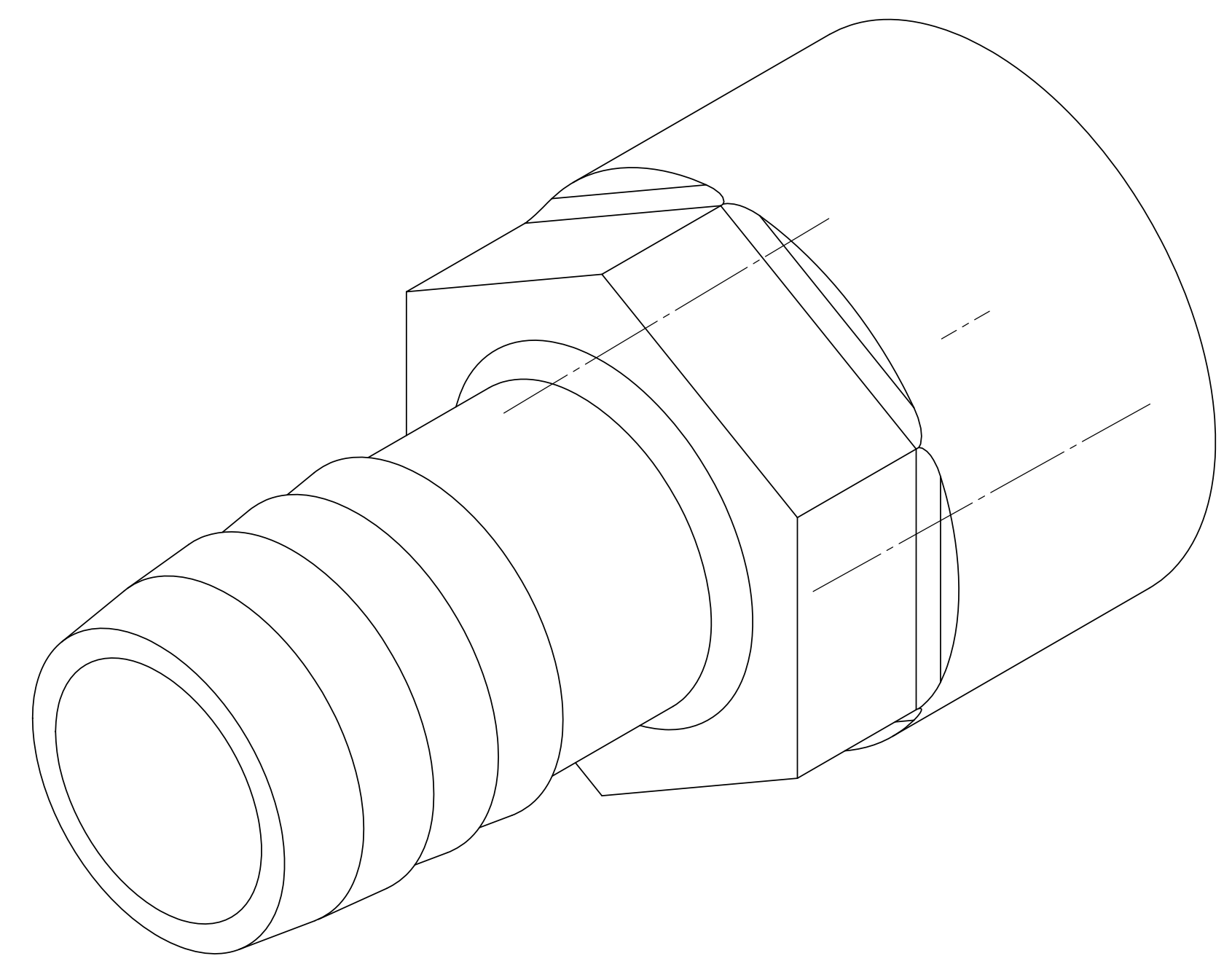

NOTES:
 1) POLYPROPYLENE HAS COLOR OPTIONS:
 BLACK = TAF101212/PPB
 NATURAL = TAF101212/PPN

SHOWN

CATALOG NO.	DESCRIPTION	MATERIAL	DIM "A"	DIM "B"	DIM "C"	DIM "D"	DIM "E"	DIM "F"	DIM "G"
TAF101212/PP	3/4" NPT X 3/4" PP	POLYPROPYLENE	.730	.380	.735	.795	1.11	2.37	1.285
TAF101212/N	3/4" NPT X 3/4" N	NYLON	.735	.375	.745	.805	1.12	2.38	1.295

PROPRIETARY AND CONFIDENTIAL
 THE INFORMATION CONTAINED IN THIS DRAWING IS THE SOLE PROPERTY OF THOGUS PRODUCTS COMPANY. ANY REPRODUCTION IN PART OR AS A WHOLE WITHOUT THE WRITTEN PERMISSION OF THOGUS PRODUCTS COMPANY IS PROHIBITED.

REV	WRO#	DESCRIPTION
D	95.00144	CONVERTED TO 3D FORMAT
UNLESS OTHERWISE SPECIFIED: DIMENSIONS ARE IN INCHES TOLERANCES: ANGULAR: ±0.5° XX.X = ± 0.1 X.XX = ± 0.05 X.XXX = ± 0.015 REMOVE ALL SHARP EDGES AND BURRS BLEND ALL RADII TO 0.01IN INTERPRET GEOMETRIC TOLERANCING PER: ANSI Y 14.5 1994 MATERIAL: PP, N FINISH: NA THIRD ANGLE PROJECTION: 		
HISTORY		

	NAME	DATE
DRAWN	JRM	05/24/11
CHECKED	KDJ	5/24/11
ENG APPR.		XX/XX/XX
MFG APPR.		XX/XX/XX
Q.A.		XX/XX/XX

Thogus You think it, we can make it...
 33490 PIN OAK, AVON LAKE, OH 44012

TITLE:
3/4" NPT FEMALE X 3/4" BARB ADAPTER

SIZE B	DWG. NO. TAF101212	REV D
SCALE: 3:2	MASS:	SHEET 1 OF 1

DO NOT SCALE DRAWING