

UNCONTROLLED IF PRINTED; CONTROLLED COPY LOCATED IN IQMS DOCUMENT CONTROL

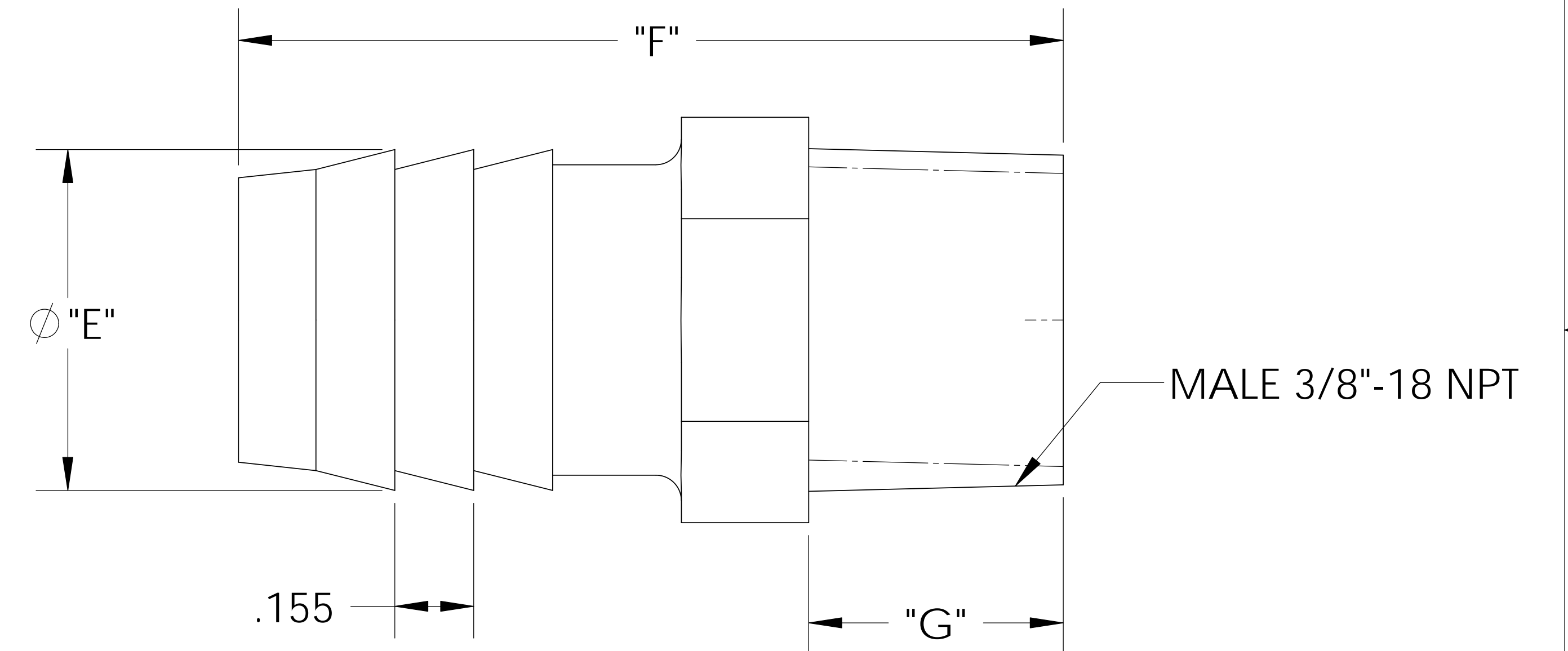
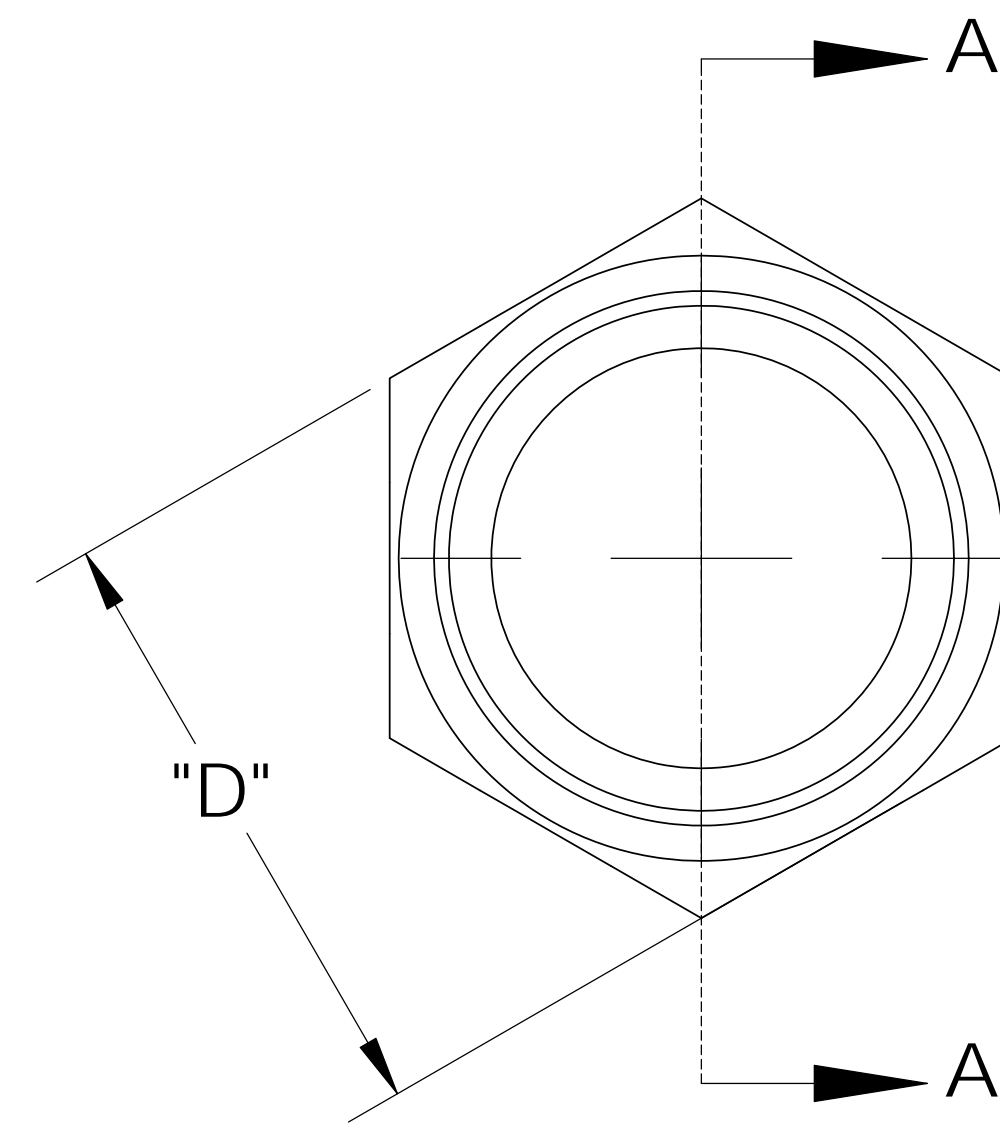
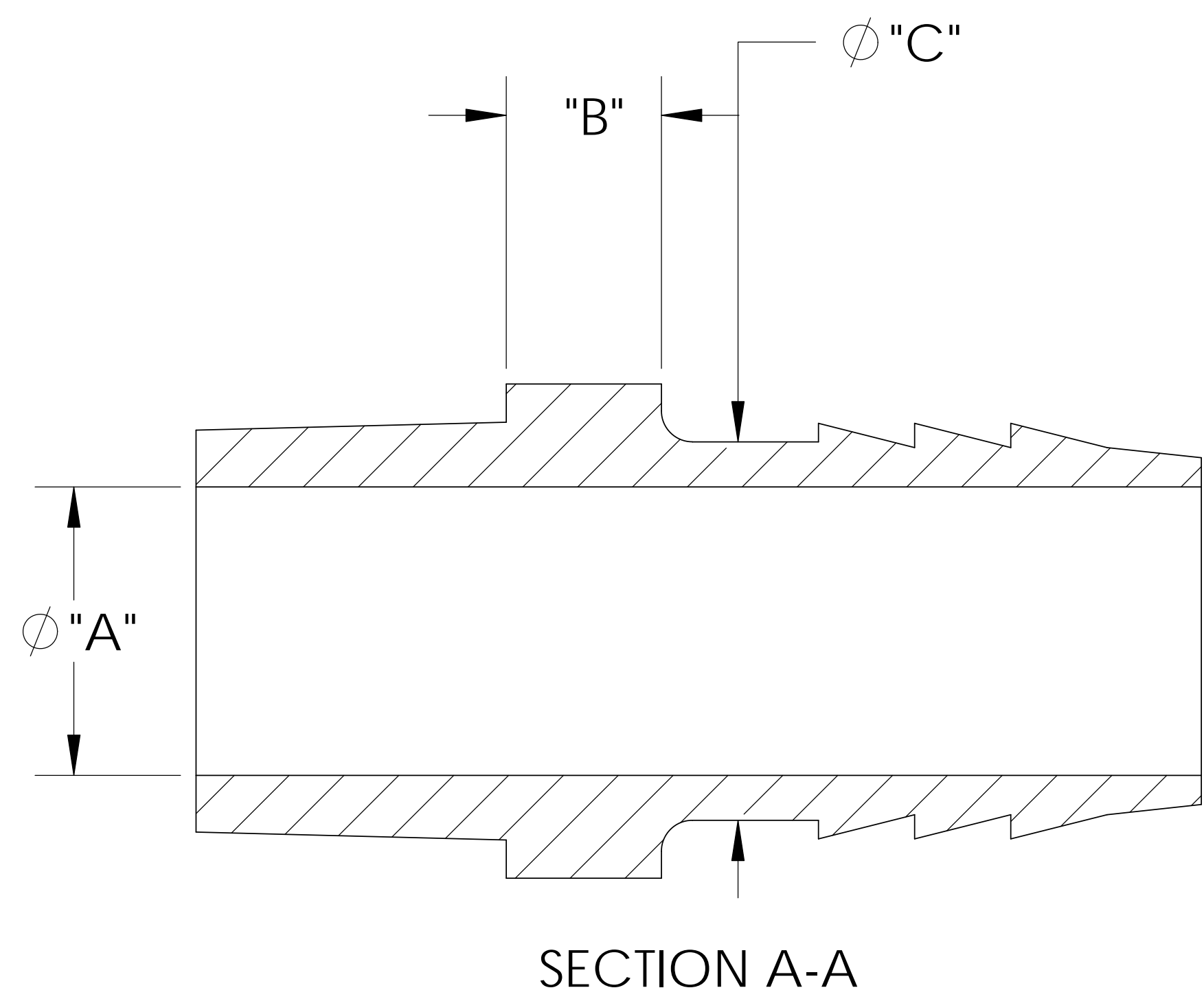
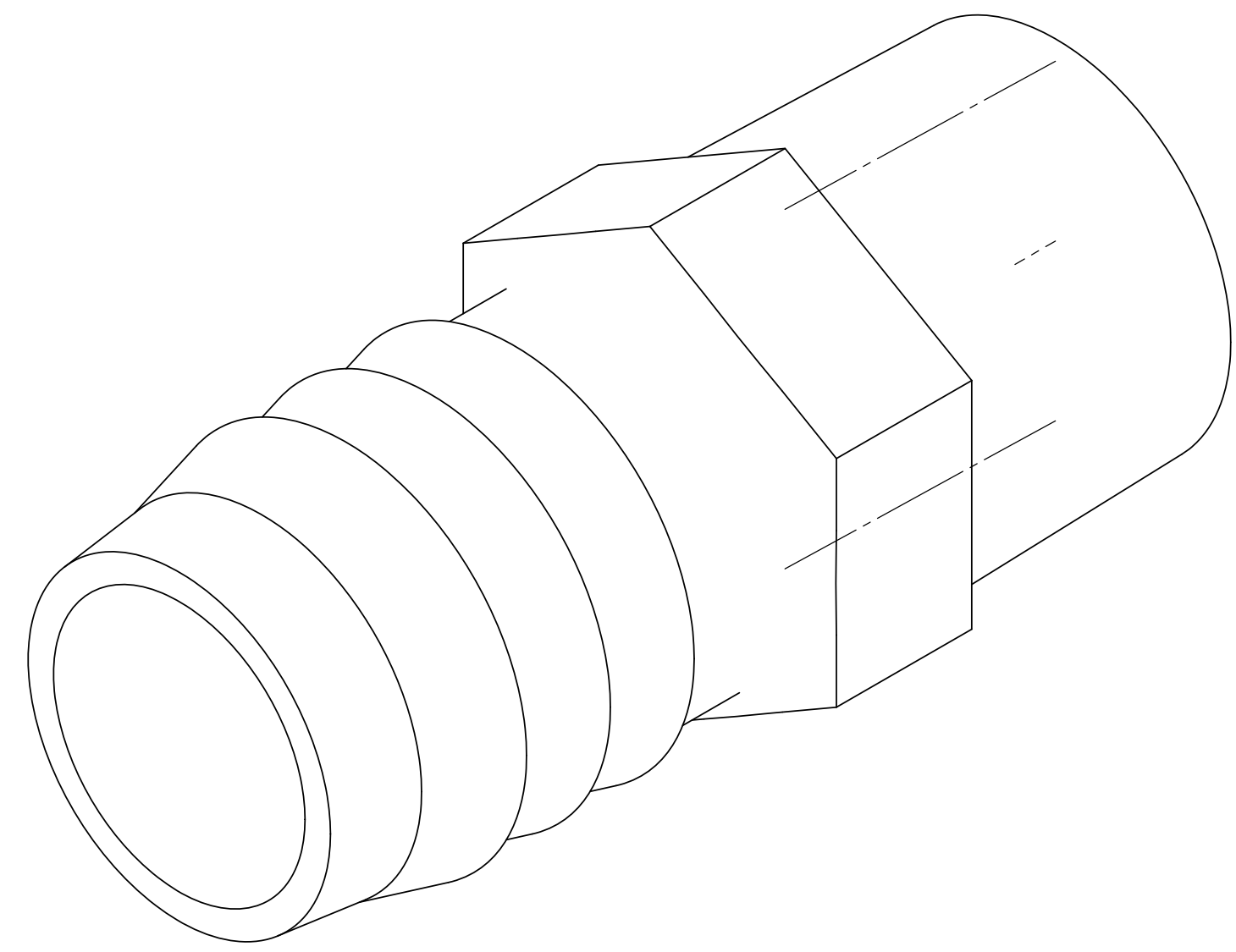

CATALOG NO.	DESCRIPTION	MATERIAL	DIM "A"	DIM "B"	DIM "C"	DIM "D"	DIM "E"	DIM "F"	DIM "G"
TA10610/PP	3/8" NPT X 5/8" PP	POLYPROPYLENE	.460	.245	.595	.69	.655	1.60	.50
TA10610/P	3/8" NPT X 5/8" P	POLYETHYLENE	.450	.245	.600	.68	.655	1.57	.49
TA10610/N	3/8" NPT X 5/8" N	NYLON	.465	.250	.610	.69	.670	1.62	.50

SHOWN

NOTES:

- POLYPROPYLENE HAS COLOR OPTIONS:
BLACK = TA10610/PPB
NATURAL = TA10610/PPN

PROPRIETARY AND CONFIDENTIAL

THE INFORMATION CONTAINED IN THIS DRAWING IS THE SOLE PROPERTY OF THOGUS PRODUCTS COMPANY. ANY REPRODUCTION IN PART OR AS A WHOLE WITHOUT THE WRITTEN PERMISSION OF THOGUS PRODUCTS COMPANY IS PROHIBITED.

REV	WRO#	DESCRIPTION
D	95.00072	CONVERTED TO 3D FORMAT

HISTORY

UNLESS OTHERWISE SPECIFIED:
DIMENSIONS ARE IN INCHES
TOLERANCES:
ANGULAR: ±0.5°
XX = ± 0.1
X.XX = ± 0.05
X.XXX = ± 0.015
REMOVE ALL SHARP EDGES AND BURRS
BLEND ALL RADII TO 0.01IN
INTERPRET GEOMETRIC TOLERANCING PER: ANSI Y 14.5 1994
MATERIAL: PP, P, N
FINISH: NA
THIRD ANGLE PROJECTION:

	NAME	DATE
DRAWN	JRM	03/17/11
CHECKED	KDJ	3/17/11
ENG APPR.	JM	3/17/11
MFG APPR.	ML	3/18/11
Q.A.	NJW	3/18/11

COMMENTS:

Thogus You think it, we can make it...
33490 PIN OAK, AVON LAKE, OH 44012
TITLE: 3/8" NPT X 5/8" BARB ADAPTER

SIZE B	DWG. NO. TA10610	REV D
SCALE: 2:1	MASS:	SHEET 1 OF 1

DO NOT SCALE DRAWING