

8 7 6 5 4 3 2 1

D
C
B
A

D
C
B
A

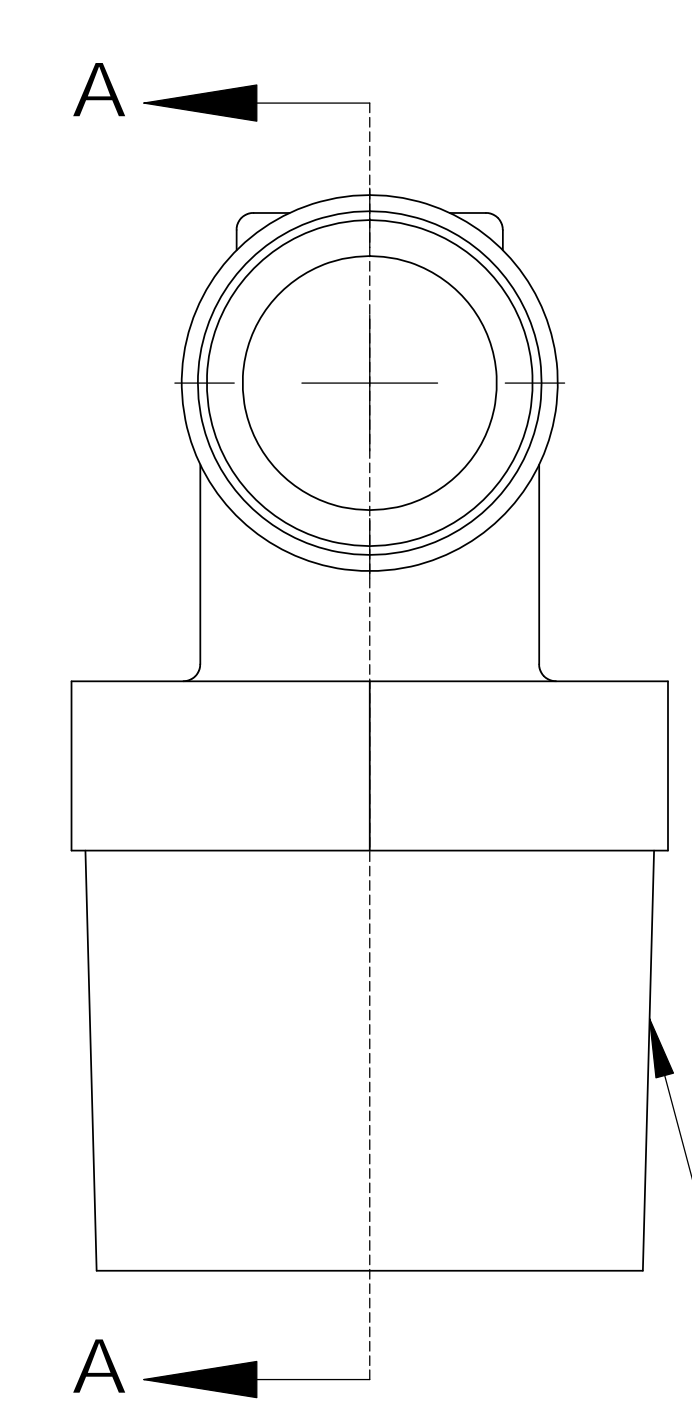
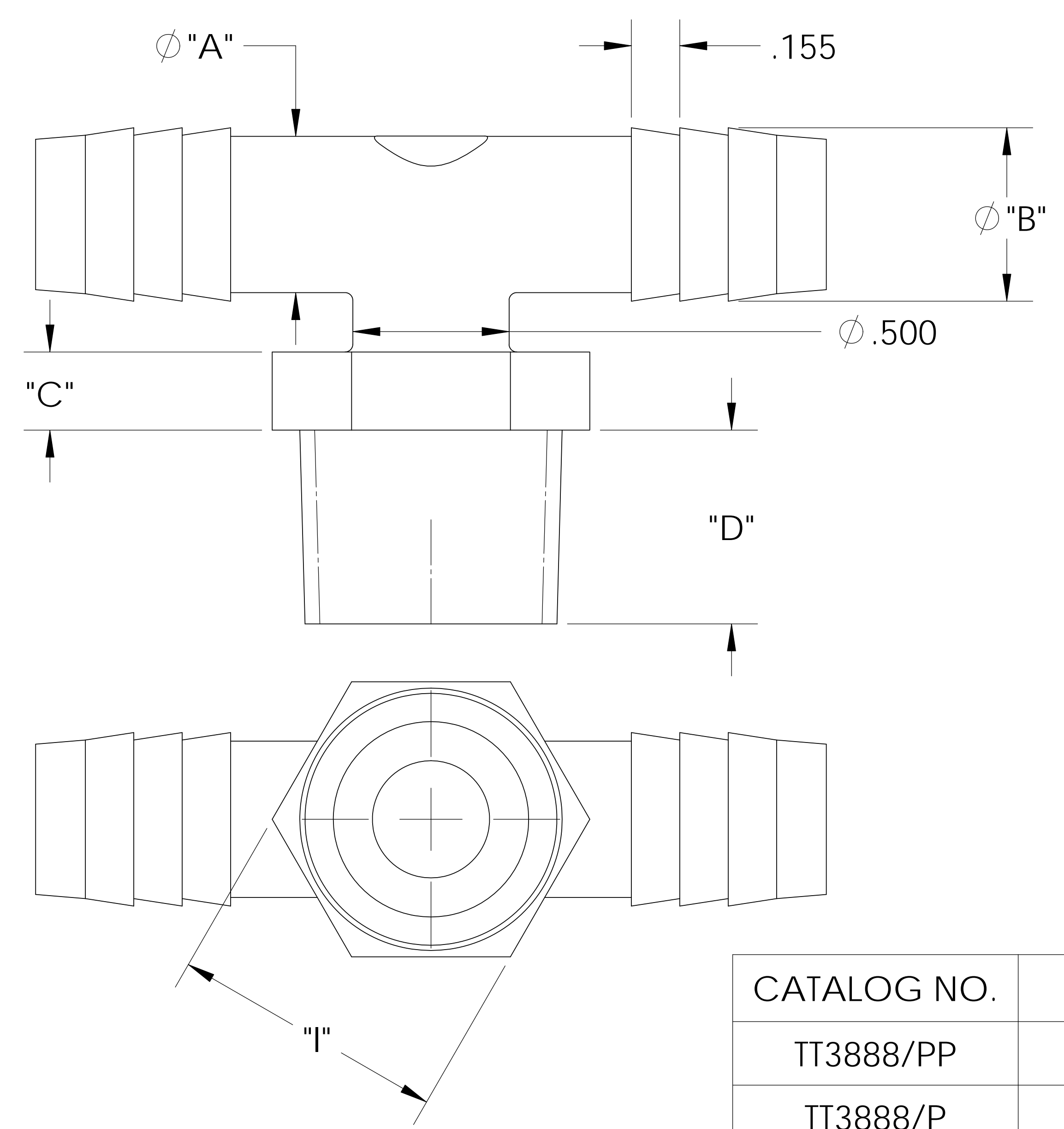
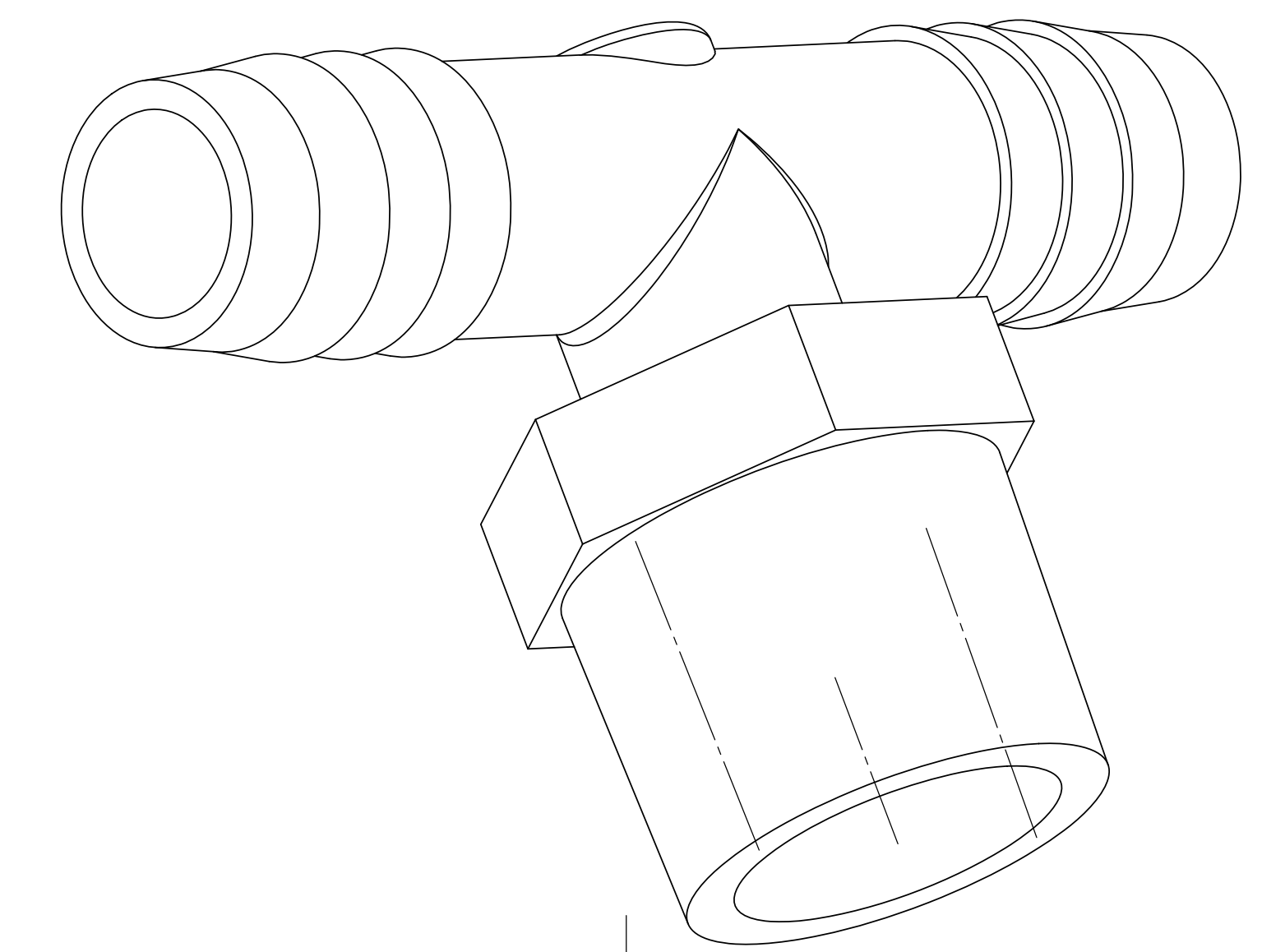

MALE 1/2"-14 NPT

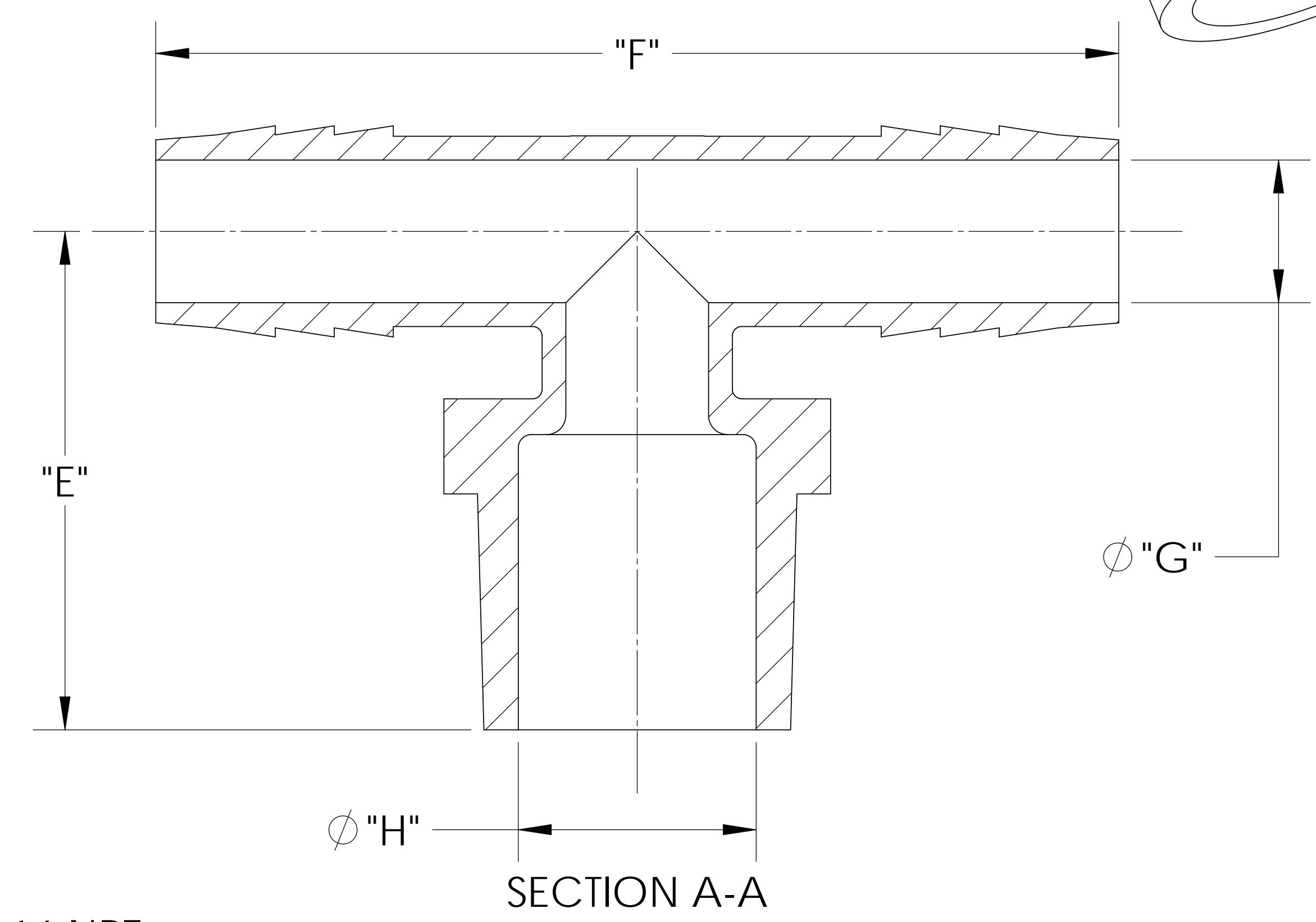

SECTION A-A

SHOWN

CATALOG NO.	DESCRIPTION	MATERIAL	DIM "A"	DIM "B"	DIM "C"	DIM "D"	DIM "E"	DIM "F"	DIM "G"	DIM "H"	DIM "I"
TT3888/PP	1/2" X 1/2" X 1/2" PP	POLYPROPYLENE	.490	.550	.240	.62	1.29	2.50	.370	.615	.86
TT3888/P	1/2" X 1/2" X 1/2" P	POLYETHYLENE	.395	.500	.24	.60	1.25	2.44	.365	.610	.86
TT3888/N	1/2" X 1/2" X 1/2" N	NYLON	.500	.555	.25	.62	1.31	2.53	.375	.625	.88

NOTES:

- 1) POLYPROPYLENE HAS COLOR OPTIONS:
BLACK = TT3888/PPB
NATURAL = TT3888/PPN

PROPRIETARY AND CONFIDENTIAL
THE INFORMATION CONTAINED IN THIS DRAWING IS THE SOLE PROPERTY OF THOGUS PRODUCTS COMPANY. ANY REPRODUCTION IN PART OR AS A WHOLE WITHOUT THE WRITTEN PERMISSION OF THOGUS PRODUCTS COMPANY IS PROHIBITED.

REV	WRO#	DESCRIPTION
D	95.00132	CONVERTED TO 3D FORMAT
HISTORY		

UNLESS OTHERWISE SPECIFIED:
DIMENSIONS ARE IN INCHES
TOLERANCES:
ANGULAR: ±0.5°
X.X = ± 0.1
X.XX = ± 0.05
X.XXX = ± 0.015
REMOVE ALL SHARP EDGES AND BURRS
BLEND ALL RADII TO 0.01IN
INTERPRET GEOMETRIC TOLERANCING PER: ANSI Y 14.5 1994
MATERIAL: PP, P, N
FINISH: NA
THIRD ANGLE PROJECTION:

	NAME	DATE
DRAWN	JRM	05/25/11
CHECKED	KDJ	05/25/2011
ENG APPR.	JM	05/26/2011
MFG APPR.	ML	05/26/2011
Q.A.	NJW	05/26/2011

Thogus You think it, we can make it...
33490 PIN OAK, AVON LAKE, OH 44012

TITLE:
1/2" NPT X 1/2" BARB X 1/2" BARB TEE

SIZE B	DWG. NO. TT3888	REV D
SCALE: 3:2	MASS:	SHEET 1 OF 1

8 7 6 5 4 3 2 1