

8 7 6 5 4 3 2 1

D
C
B
A

D
C
B
A

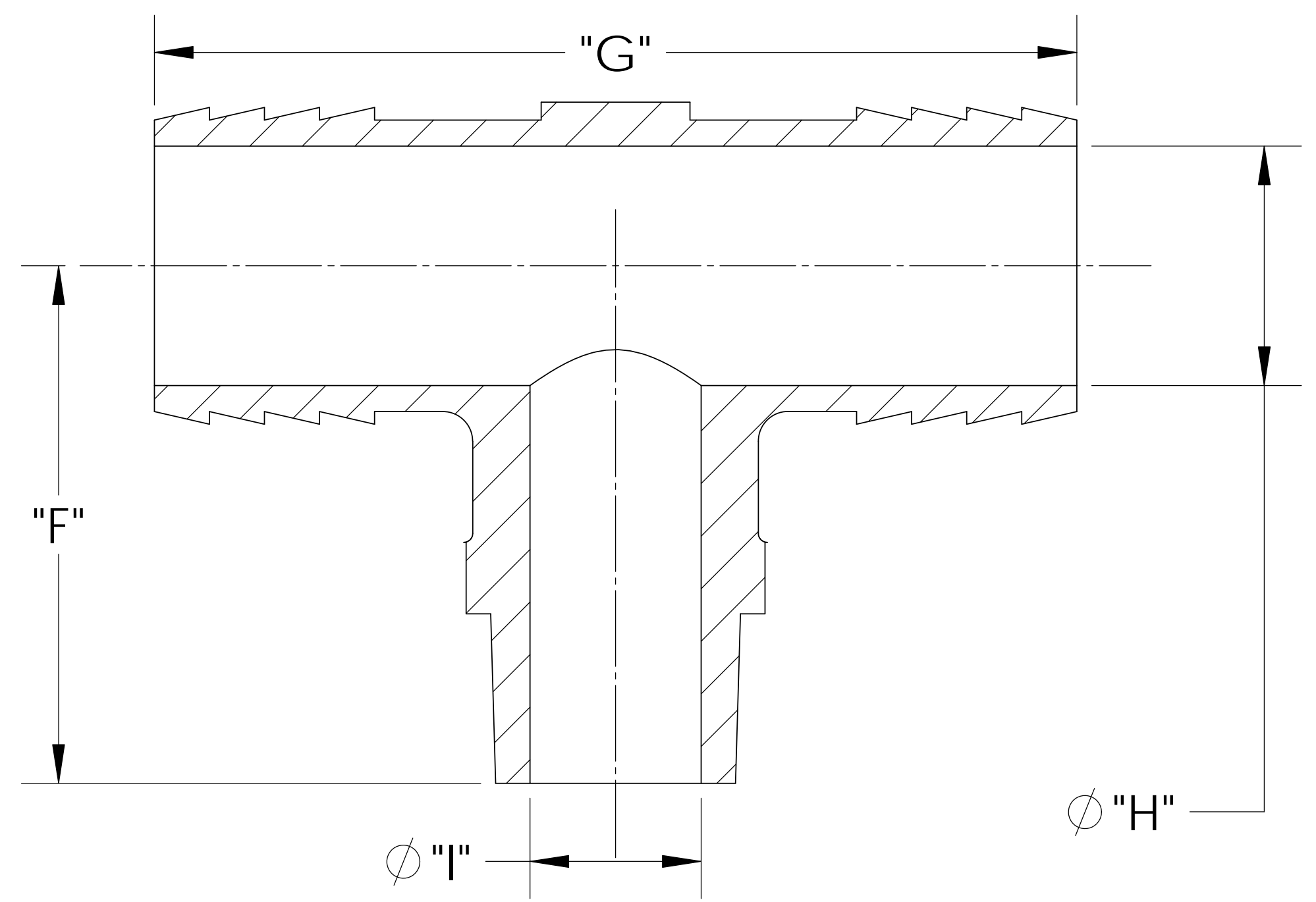
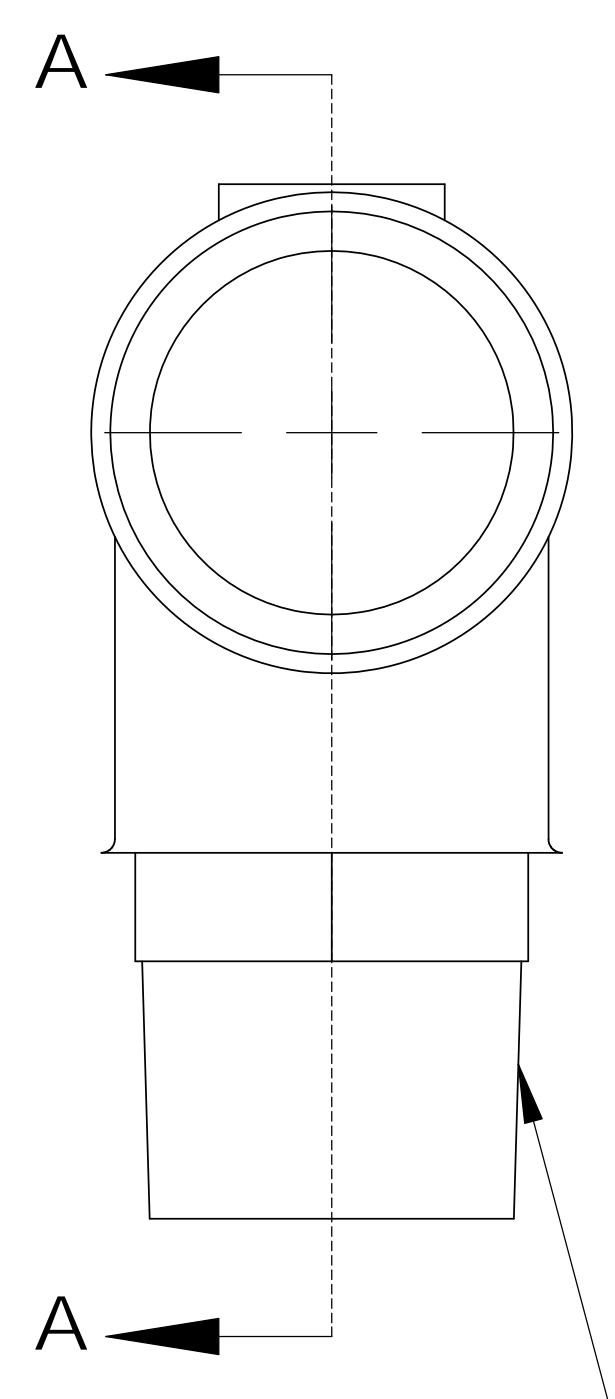
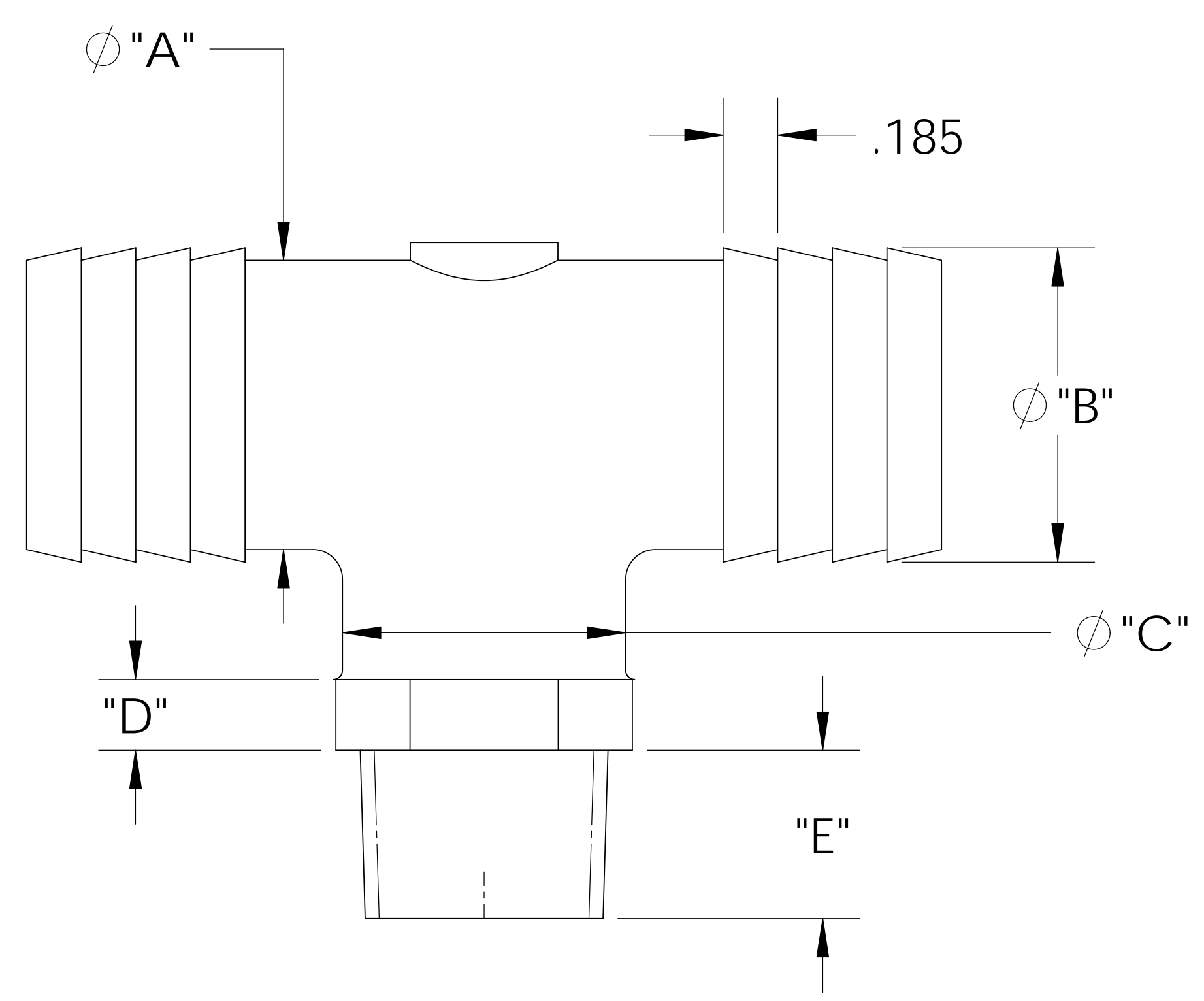
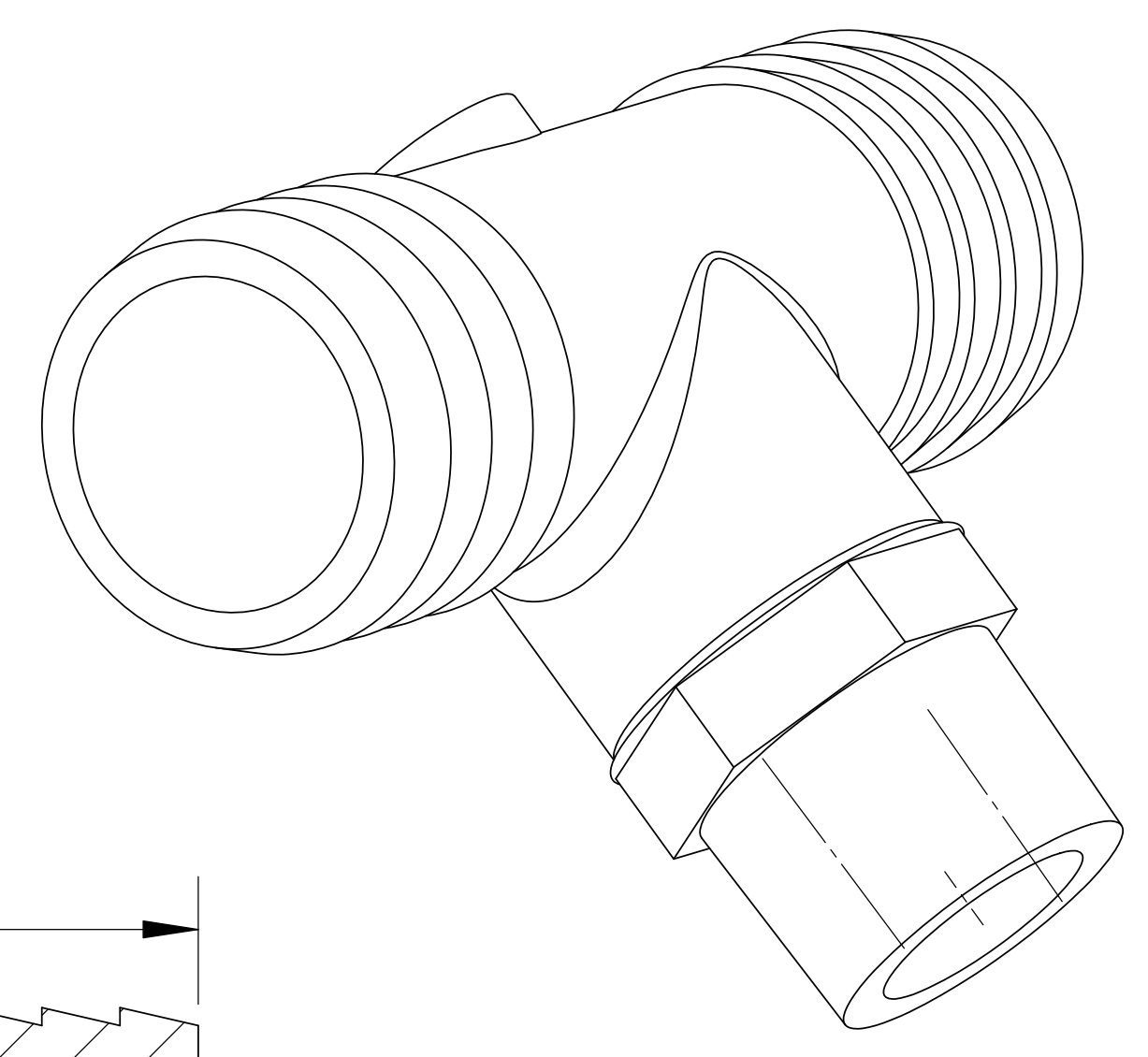

SECTION A-A

MALE 1/2"-14 NPT

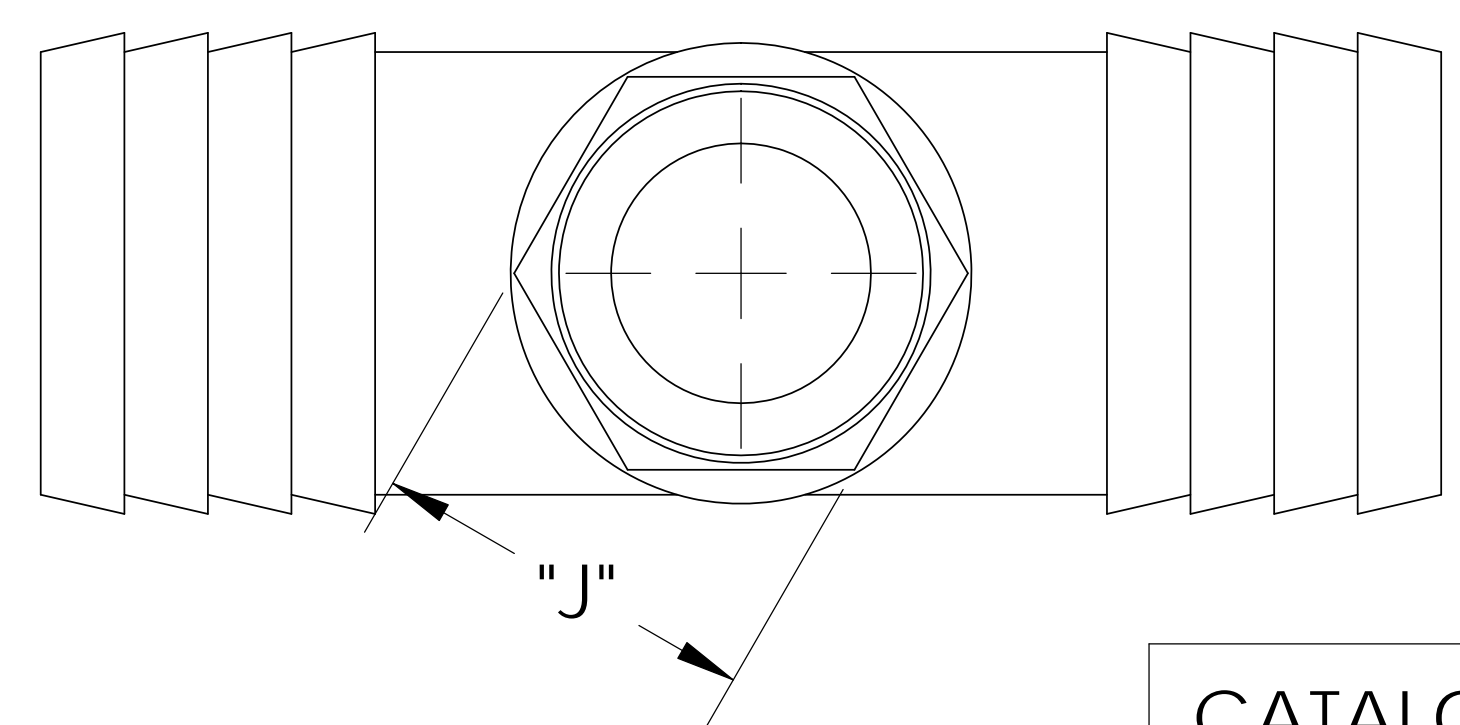

SHOWN

CATALOG NO.	DESCRIPTION	MATERIAL	DIM "A"	DIM "B"	DIM "C"	DIM "D"	DIM "E"	DIM "F"	DIM "G"	DIM "H"	DIM "I"	DIM "J"
TT381616/PP	1/2" X 1" X 1" PP	POLYPROPYLENE	.970	1.060	.950	.23	.56	1.72	3.07	.795	.570	.86
TT381616/P	1/2" X 1" X 1" P	POLYETHYLENE	.9900	1.060	.9900	.2500	.625	1.73	3.10	.800	.575	.875
TT381616/N	1/2" X 1" X 1" N	NYLON	.980	1.065	.960	.24	.57	1.74	3.10	.805	.575	.87

NOTES:

- 1) POLYPROPYLENE HAS COLOR OPTIONS:
BLACK = TT381616/PPB
NATURAL = TT381616/PPN
- 2) DIMENSIONS FOR POLYETHYLENE NOT CHECKED

PROPRIETARY AND CONFIDENTIAL
THE INFORMATION CONTAINED IN THIS DRAWING IS THE SOLE PROPERTY OF THOGUS PRODUCTS COMPANY. ANY REPRODUCTION IN PART OR AS A WHOLE WITHOUT THE WRITTEN PERMISSION OF THOGUS PRODUCTS COMPANY IS PROHIBITED.

REV	WRO#	DESCRIPTION
D	95.00132	CONVERTED TO 3D FORMAT
HISTORY		

UNLESS OTHERWISE SPECIFIED:
DIMENSIONS ARE IN INCHES
TOLERANCES:
ANGULAR: ±0.5°
X.X = ± 0.1
X.XX = ± 0.05
X.XXX = ± 0.015
REMOVE ALL SHARP EDGES AND BURRS
BLEND ALL RADII TO 0.01IN
INTERPRET GEOMETRIC TOLERANCING PER: ANSI Y 14.5 1994
MATERIAL: PP, P, N
FINISH: NA
THIRD ANGLE PROJECTION:

	NAME	DATE
DRAWN	JRM	05/26/11
CHECKED	KDJ	05/26/11
ENG APPR.		XX/XX/XX
MFG APPR.		XX/XX/XX
Q.A.		XX/XX/XX

Thogus You think it, we can make it...
33490 PIN OAK, AVON LAKE, OH 44012

TITLE:
1/2" NPT X 1" BARB X 1" BARB TEE

SIZE B	DWG. NO. TT381616	REV D
------------------	----------------------	-----------------

DO NOT SCALE DRAWING SCALE: 1:1 MASS: SHEET 1 OF 1

8 7 6 5 4 3 2 1