

UNCONTROLLED IF PRINTED; CONTROLLED COPY LOCATED IN IQMS DOCUMENT CONTROL

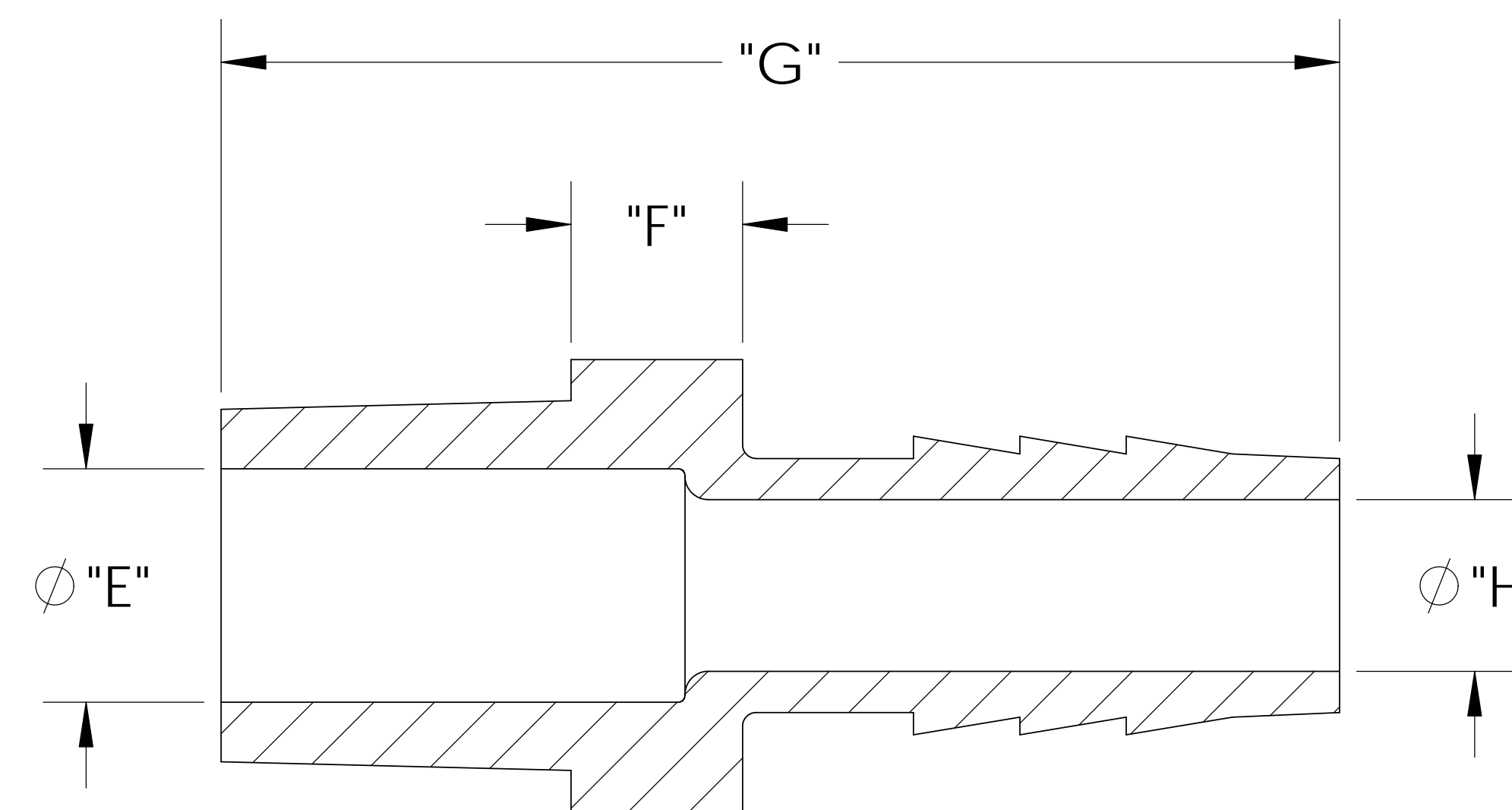
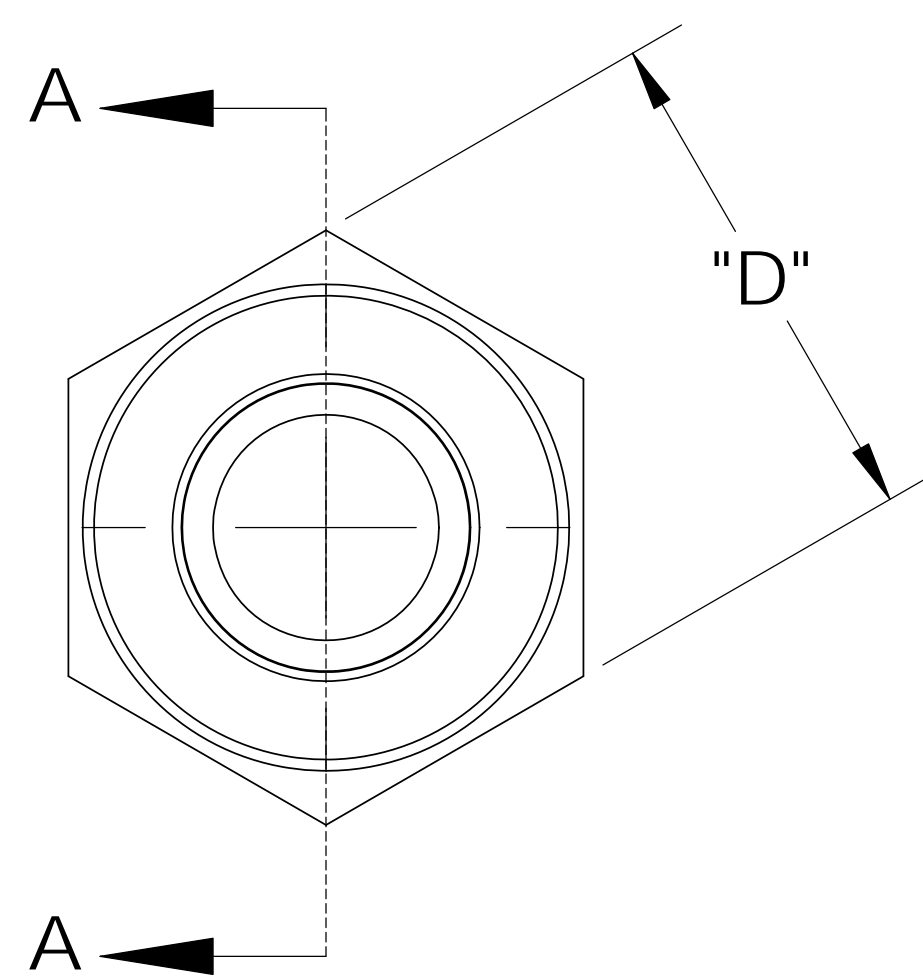
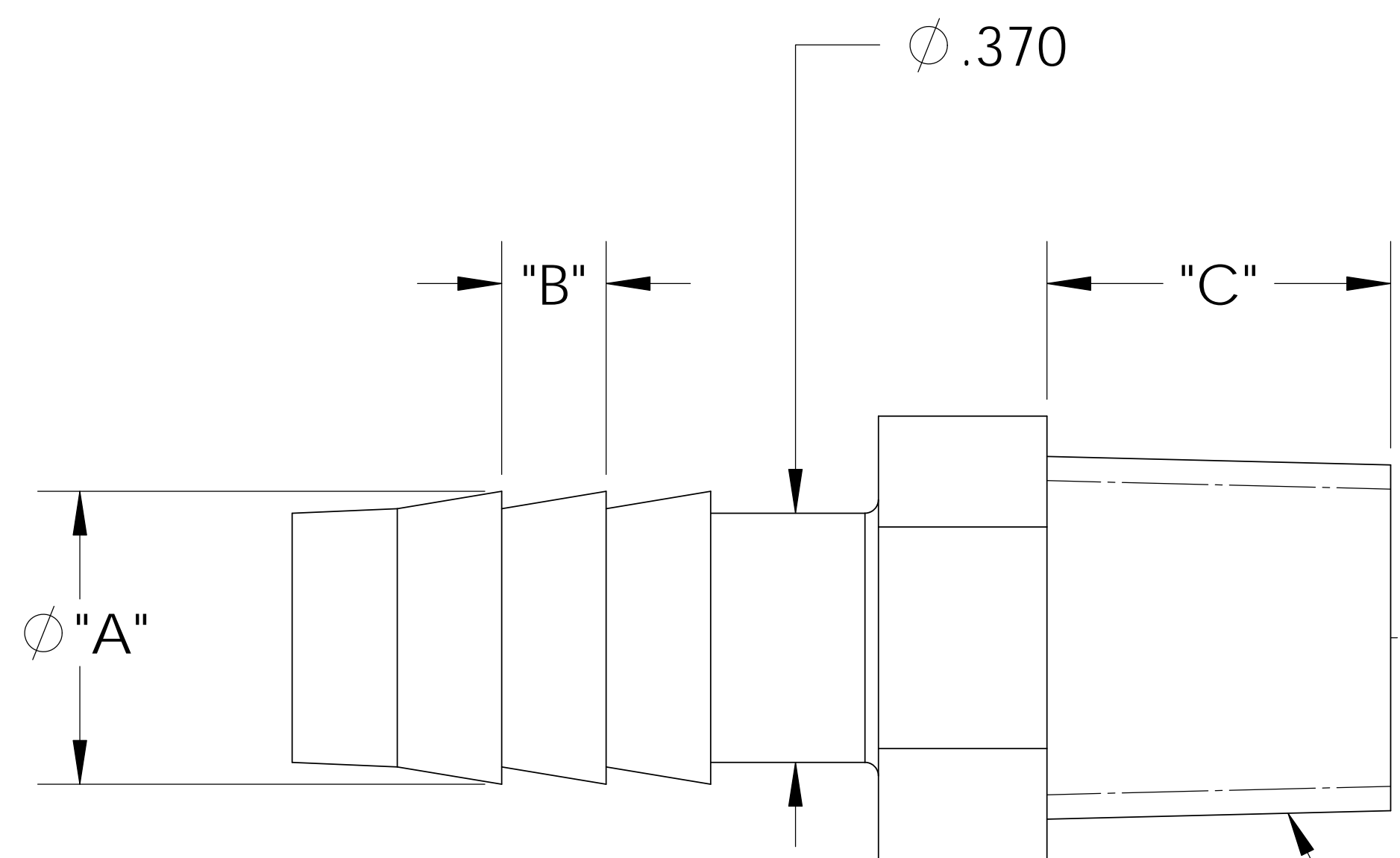
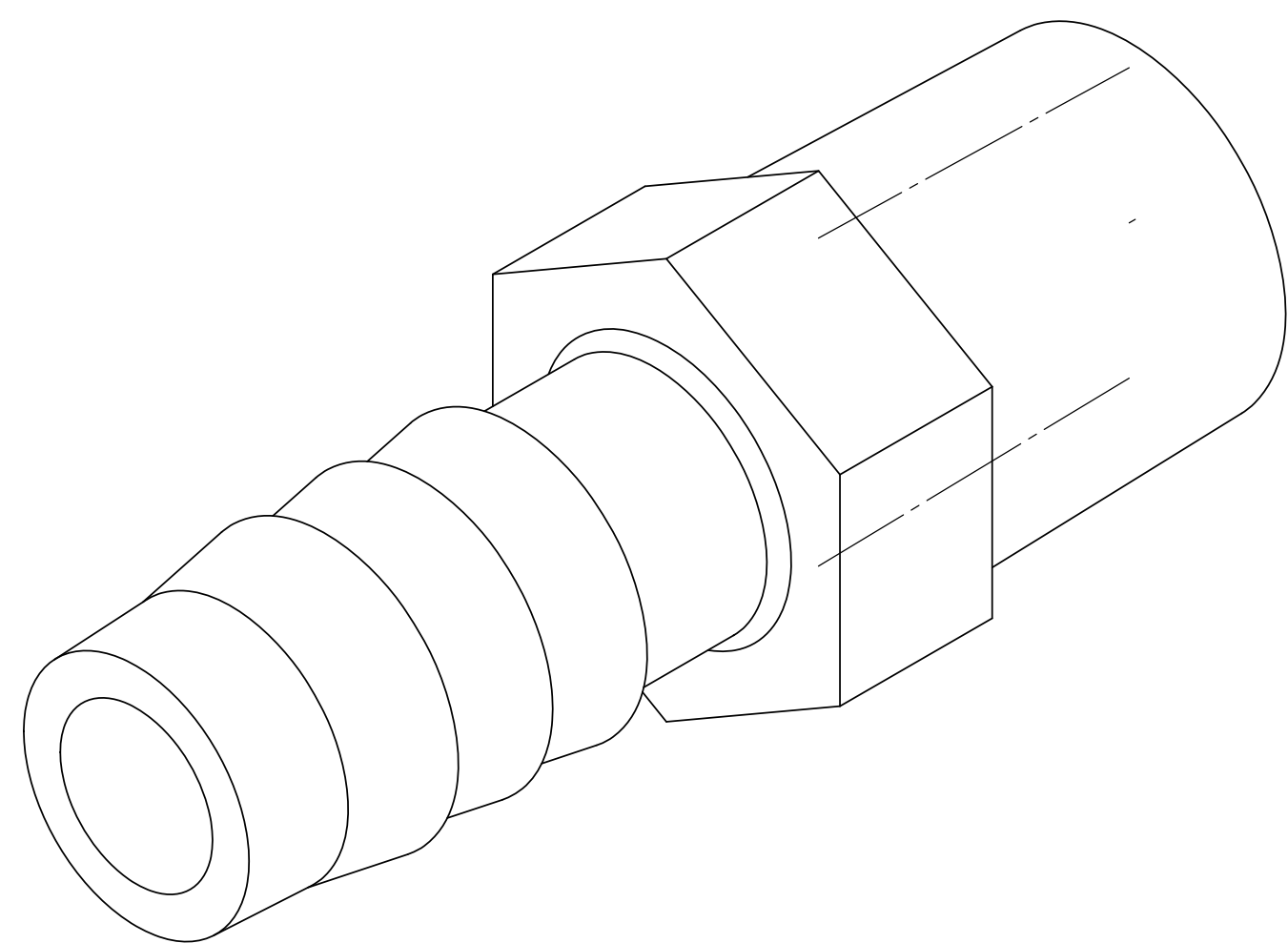

SECTION A-A

MALE 1/4"-18 NPT

CATALOG NO.	DESCRIPTION	MATERIAL	DIM "A"	DIM "B"	DIM "C"	DIM "D"	DIM "E"	DIM "F"	DIM "G"	DIM "H"
TA1046/PP	1/4" NPT X 3/8" PP	POLYPROPYLENE	.430	.155	.50	.56	.335	.250	1.60	.245
TA1046/P	1/4" NPT X 3/8" P	POLYETHYLENE	.430	.150	.49	.55	.335	.245	1.57	.240
SHOWN TA1046/N	1/4" NPT X 3/8" N	NYLON	.435	.155	.51	.57	.340	.250	1.63	.250

NOTES:

- 1) POLYPROPYLENE HAS COLOR OPTIONS:
 BLACK = TA1046/PPB
 NATURAL = TA1046/PPN

PROPRIETARY AND CONFIDENTIAL
 THE INFORMATION CONTAINED IN THIS DRAWING IS THE SOLE PROPERTY OF THOGUS PRODUCTS COMPANY. ANY REPRODUCTION IN PART OR AS A WHOLE WITHOUT THE WRITTEN PERMISSION OF THOGUS PRODUCTS COMPANY IS PROHIBITED.

REV	WRO#	DESCRIPTION
D	95.00072	CONVERTED TO 3D FORMAT
HISTORY		

UNLESS OTHERWISE SPECIFIED:
 DIMENSIONS ARE IN INCHES
 TOLERANCES:
 ANGULAR: ±0.5°
 XX = ± 0.1
 X.XX = ± 0.05
 X.XXX = ± 0.015
 REMOVE ALL SHARP EDGES AND BURRS
 BLEND ALL RADII TO 0.01IN
 INTERPRET GEOMETRIC TOLERANCING PER: ANSI Y 14.5 1994
 MATERIAL: PP, P, N
 FINISH: NA
 THIRD ANGLE PROJECTION:

	NAME	DATE
DRAWN	JRM	03/17/11
CHECKED	KDJ	03/17/2011
ENG APPR.	JM	03/18/2011
MFG APPR.	ML	03/18/2011
Q.A.	NJW	03/18/2011

Thogus You think it, we can make it...
 33490 PIN OAK, AVON LAKE, OH 44012

TITLE: **1/4" NPT X 3/8" BARB ADAPTER**

SIZE B	DWG. NO. TA1046	REV D
SCALE: 2:1	MASS:	SHEET 1 OF 1

DO NOT SCALE DRAWING